

LEOK-4

Geometrical Optics Experiment Kit

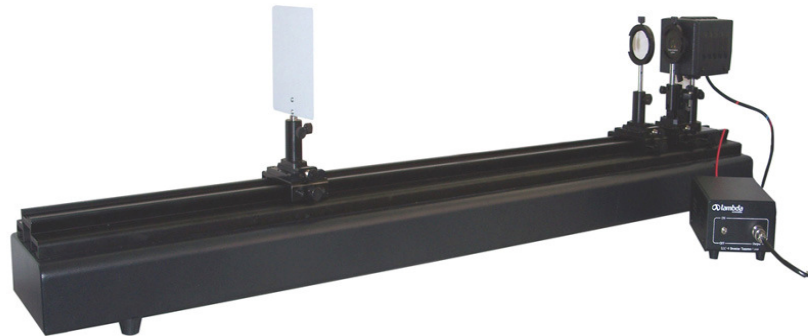

- *Easy Operation*
- *9 Experimentts*
- *Complete Solution*
- *Extensive Document*

This kit provides complete set of optical and mechanical components as well as light sources, which can be conveniently assembled to construct experimental setup of geometrical optics. Through selecting and assembling the corresponding components into the setups by students themselves, their experimental skills and problem solving ability can be greatly enhanced.

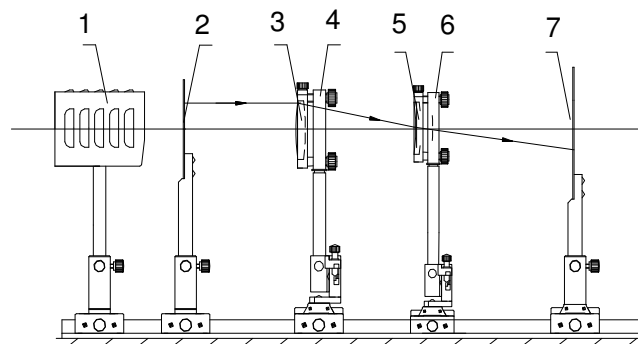

- | | |
|---|--|
| 1: Bromine Tungsten Lamp (LLC-4) | 5: Concave Lens ($f = -60\text{mm}$) |
| 2: Object Screen | 6: Two-axis Tilt Holder (LEPO-8) |
| 3: Convex Lens ($f' = 190\text{ mm}$) | 7: White Screen |
| 4: Two-axis Tilt Holder (LEPO-8) | |

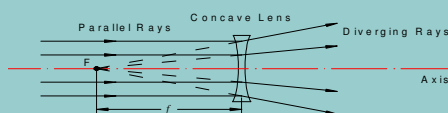

a Concave Lens

An illustration of determination of Focal Length of a Concave Lens' setup

Experiment examples

- Measuring focal length of a positive thin lens by measuring object length and image length
- Measuring the Focal Length of a Positive Thin Lens Using Auto-collimation
- Measuring the Focal Length of a Positive Lens Using Displacement Method
- Measuring the Focal Length of a Concave Lens
- Measuring Focal Length of an Eyepiece
- Measuring the Nodal Locations and Focal Lengths of a Lens-Group
- Assembling a Microscope
- Assembling a Telescope
- Assembling a Slide Projector

Parts Included

Description	Specs/Model	Qty
Optical rail and base		1
Carrier	LEOK-4-1	1
Carrier	LEOK-4-2	2
Carrier	LEOK-4-3	2
Bromine-Tungsten lamp	LLC-4	2 set
Two axis tilt-able holder	LEPO-8	1
Lens holder	LEPO-9	2
Adaptor piece	LEPO-10	1
Lens group holder	LEPO-29	1
Microscope eyepiece		1
DMM holder	LEPO-37	1
Plate holder	LEPO-13	1
White screen	LEPO-14	1
Object screen	LEPO-15	1
Ruler	LEPO-34	1
Reticles	1/10mm	1
Millimeter	$l = 30\text{mm}$	1
Biprism	LEPO-43	1
Lens	$f = 45, 50, 100, -60, 150, 190$	1 for each
Plane mirror	$\phi 36 \times 4$	1
45° glass holder	SZ-45	1
Eyepiece	$f = 29\text{mm}$	1
Slide		1